

# BEATLES TRADERS

## TDS OF PERFORATED RELEASE FILM

Basic purpose of the release film is to ensure the proper release of the helping material use for vacuum bagging. Release films are placed directly in contact with the laminate. Release films are often perforated in order to ensure that anytrapped air, volatiles or excess resin, which may affect the physical properties of the laminate, can be removed.

### Physical properties:

Description	Property	Method
Product name	Perforated release film	
Material	High density polyethylene	
Width	1500MM	
Thickness	27Microns (+/- 5%)	ASTM E 252
Tensile strength at break	MIN 35 Kg/mm <sup>2</sup> (+/- 5%)	ASTM D 882
Elongation at break	≥ 390 %	ASTM D 882
Melting point	127°C	ASTM D 1525
Density	≥ 0.950 g/cm <sup>3</sup>	
Color	Reddish/Blue	

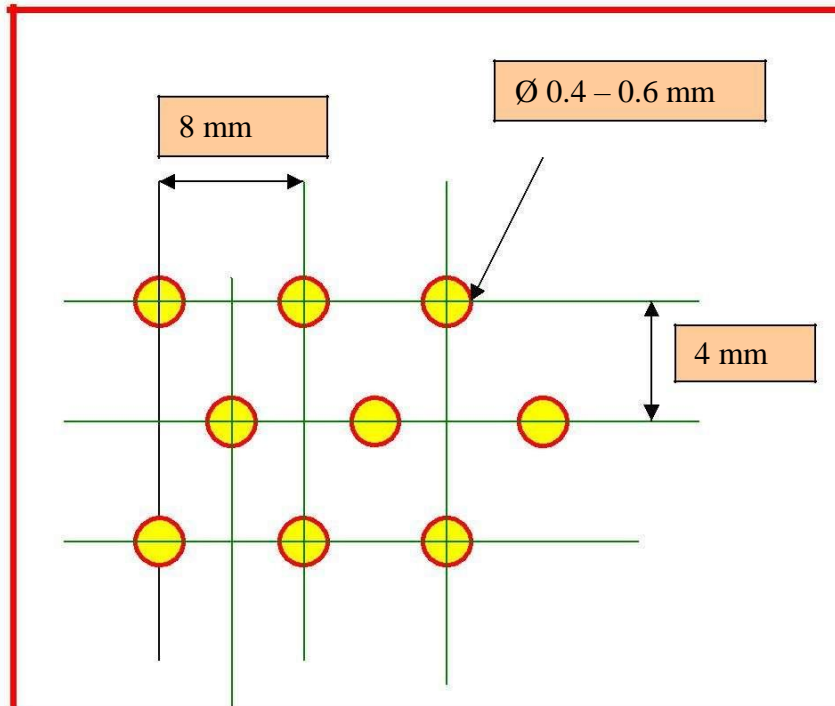

GST NO. 24COIPG2681H1ZZ

C 309, Shivam vihar Umbergaon-396165  
District Valsad  
Phone no.: +91 9624692477  
Email: [beatlestraders@gmail.com](mailto:beatlestraders@gmail.com)